

## INWARD-OPENING LETTERPLATE

When we developed the TS008 system we always envisaged introducing a range of different products that could mix and match to give our customers a wide variety of options covering different styles of doors and different end users. We developed the first TS008 based on our Framemaster design which has been popular for the last 20 years. We then developed a Slim Internal to give a sleeker design and this is very popular now in New Build. We know that the New Build markets and the emerging Retail market with changes to security will need to offer the end consumer additional choice.

We therefore developed 2 new external letterplate components that can match to Soterian Slim seamlessly.

*The first is our Inward Opening system*

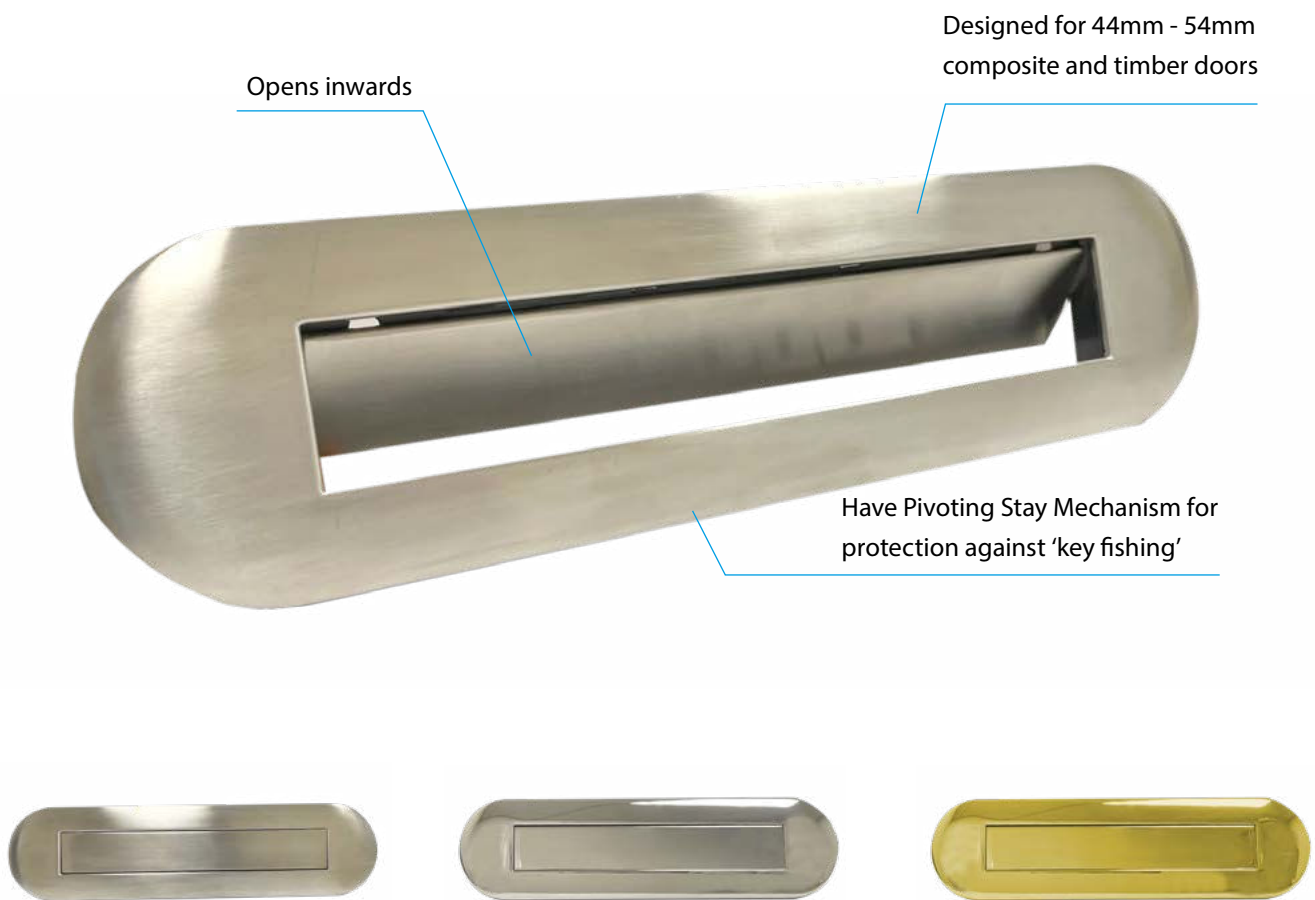

The design concept was to develop a letterplate that was the opposite to the existing letterplate on the market with a flap coming outwards. We went back in time and studied Victorian letterplates and the ever popular inward opening systems that have been in existence for generations. We took that concept and then added our Nanocoast technology to it to give it a long lasting, super shiny surface finish. And then we made the feel and look modern with its rounded and bevelled edges. The look is a super sleek, high quality, modern looking letterplate that will enhance any door.

Available in 3 finishes, Mirror Polished Stainless Steel, Satin Stainless Steel and PVD Gold coated Stainless Steel, these products are perfect for any high end retail application.

## Features Include:

- Designed for 44mm - 54mm composite and timber doors
- Opens inwards like a traditional letterplate
- Will be teamed with the Soterian Slim internal section which is the most compact letterplate on the market. This allows for full unrestricted door opening
- Pivoting stay mechanism reduces internal flap opening for protection against 'key fishing' and lock manipulation
- There are no fixings to the exterior of the letterplate, preventing the outer frame being unscrewed from the door externally
- Quick and easy five step fitting

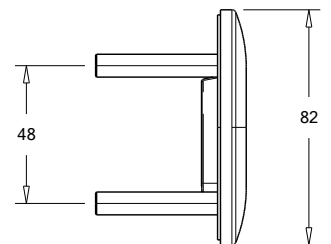
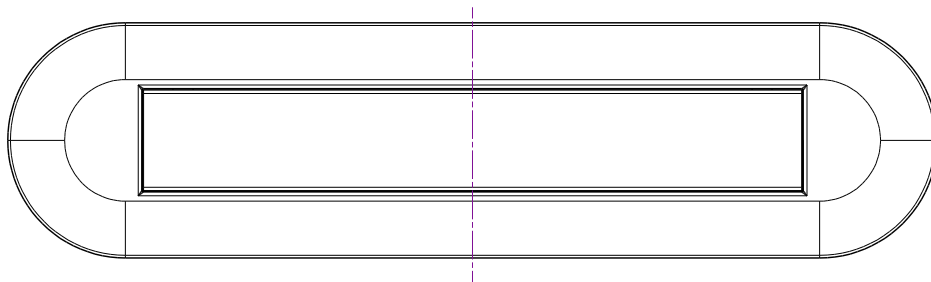
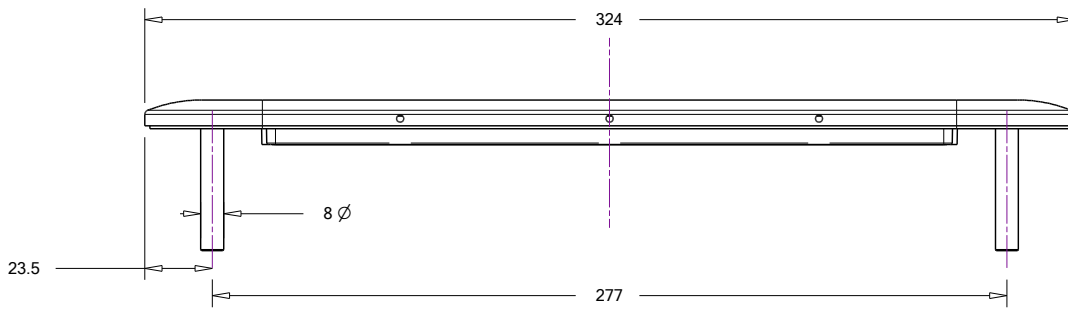

## Measurements:

Length: 324mm

Height: 82mm

Distance between screws: 277mm

Opening: 230mm x 36mm