

Adapt A Lever

High quality stainless steel handle adjusted to your needs.

The Intelligent Hardware stainless steel Adapt A Handle features an adaptable handle height to accommodate both inline and offset centres between 59-96mm and adaptable screw centres. The adjustable handle is ideal solution, for installers looking to reduce the amount of van stock they carry. This handle features the sliding mechanism fitted with a nylon seal for ingress protection. The bottom fixing bolt will fit through all the handles on the market. The top bolt is positioned to fit most locks by being longer than normal. The Adapt A Lever handle is supplied complete with all plates, 8mm solid spindle, fixings and an allen key.

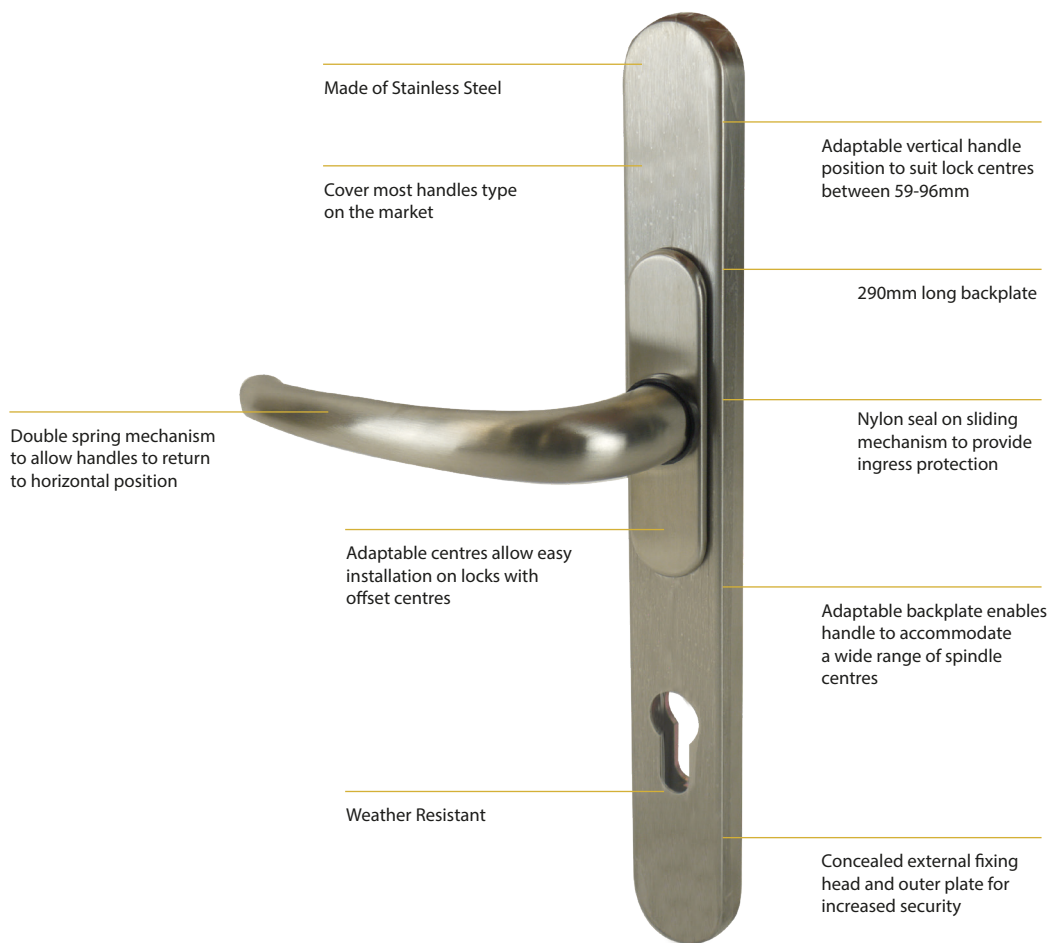

Product	Code
ADAPT-A-LEVER PB-PVD EURO PROFILE LEVER HANDLE	IH-ADAPT.A.LEVER.PB-PVD
ADAPT-A-LEVER PSS EURO PROFILE ADJ LEVER HANDLE	IH-ADAPT.A.LEVER.PSS
ADAPT-A-LEVER SATIN EURO PROFILE LEVER HANDLE	IH-ADAPT.A.LEVER.SSS
ADAPT-A-LEVER WHITE EURO PROFILE LEVER HANDLE	IH-ADAPT.A.LEVER.WHT

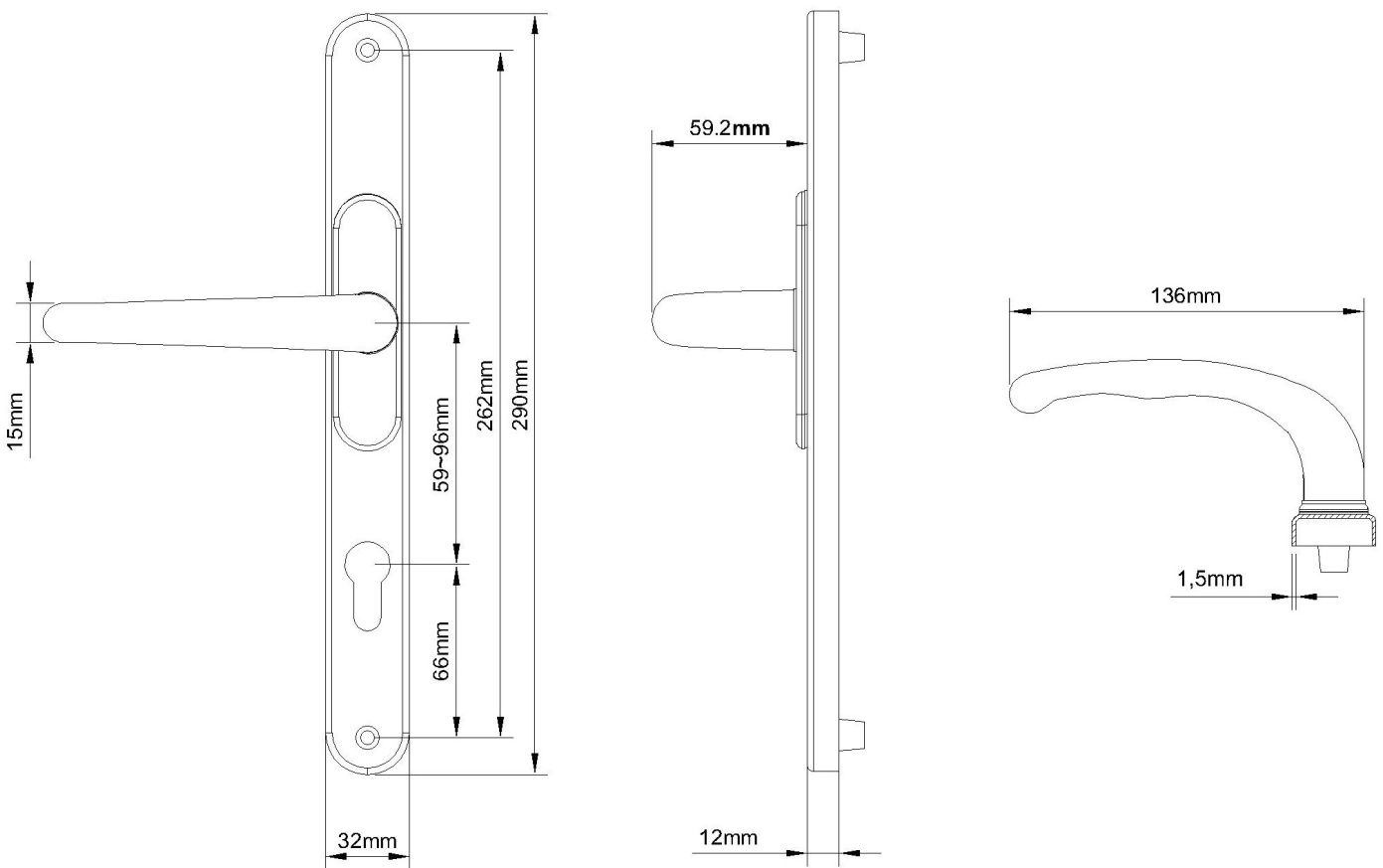

Technical Info

Centres 59mm to 96mm (adjustable)
 Faceplate Width 32mm
 Screw Centres 262mm
 Spindle 8mm
 Pack Quantity 1 Pair

*Handle adjusted
to your needs*